



MEMFlo "PVC & CPVC™" FLOWMETERS

Features & Benefits

- Heavy bodied meters for corrosives and high purity fluids.
- Ideal for acids & caustics, deionized water, plating solutions, water treatment, & corrosive gases.
- All plastic wetted components (unless glass sight tube option requested) for maximum corrosion resistance.
- Extended flow ranges averaging 25 to 1.
- Disassembles in less than a minute without removing the meter from the pipeline.
- Offered in transparent tube models for clear fluids or magnetic indication for opaque fluids.
- Standard female NPT for 3/4, 1 1/2, & 2 1/2 meters, Van Stone style flanges for 3 1/2 & 4 1/2 models. All sizes available in threaded, socket, or Van Stone flanged connections.
- Most models can be supplied with Flo-Sentry Alarms, KIST 4-20mA, and Courier Remote Transmitters as well as other MEMFlo options & accessories.
- Economically priced, with standard deliveries of 2 weeks for most models.

Specifications

Accuracy: ±2% of 100% flow rate.

Repeatability: ±1/2% of indicated flow rate.

Rangeability: 25 to 1 average.

Materials: All wetted parts (except static "O" ring seal) PVC on PVC models, CPVC & polysulfone or all CPVC on CPVC units. Glass sight tubes can be ordered.

Standard direct reading (GPM or LPM Liquid, Sp. Gr. = 1.00 or SCFM Dry Air @100 psig, 70°F.) or percentage scale. Scales are special corrosion-resistant mylar or polyester materials. Special scales for other flow units or media

conditions, are available at extra cost. Scale length is approximately 3.2" for Size 6 meters, 5.2" on Size 12 units.

Pressure Rating: Up to 150 psig for flanged models, or 300 psig, depending on meter type, temperature, and service conditions. Operating limits of P-72 are basically the same as CPVC.

Temperature Rating: Up to 212°F. (pressure ratings decrease at higher temperatures).

"O" Rings: Buna N standard; Viton, Ethylene-Propylene (EPR), Silicone, Neoprene, and Teflon optional.

Sight Tube Options

PVC: Transparent, molded PVC sight tube with same chemical resistance as standard Type 1, Grade 1 PVC.

Resistant to many acids, alkalis, salt solutions, and other corrosives. Attacked by nonpolar solvents including some chlorinated hydrocarbons, and aromatics. Maximum temperature 140°F.

CPVC (uses magnetic indication): These molded tubes are CPVC Type 4, Grade 1, and have physical properties similar to PVC at room temperature. The chemical resistance of CPVC is generally superior to PVC. CPVC has a maximum service temperature of 210°F., making it an excellent material for fluids at temperatures beyond the capability of PVC.

POLYSULFONE: Only offered on CPVC flowmeters for compatible fluids that are transparent or translucent. Highly resistant to many aqueous mineral acids, alkali, and salt solutions; good resistance to detergents and hydrocarbon oils. Temperatures to 300°F. (well above the limit of CPVC). Attacked by nonpolar organic solvents such as ketones, halogenated hydrocarbons, and aromatic hydrocarbons.

BOROSILICATE GLASS: Satisfactory for most acids, hot solutions (to 240°F.) below pH-12, and strong alkalis (to 20%) up to 100°F.

Not recommended for water above 200°F., steam, fluorine, or hydrofluoric acid. Temperatures to 400°F. acceptable with non-attacking fluids. Glass sight tubes are permanently bonded in a PVC or CPVC (to match meter material) sleeve for mounting to the meter body. An optional Safety Guard Tube that attaches to the sleeve is strongly recommended.

OPTIONS: Flanged, threaded, or socket weld connections in standard or special sizes, Flo-Sentry™ Alarms, Flow or Mass Courier™ Systems, panel mount kits, special or multiple scaling, & safety devices available. Custom options such as viscosity calibrations are by quotation only.

CALIBRATION TRACEABILITY

Each MEMFlo Flowmeter is individually calibrated on test facilities designed and operated according to applicable ASME, ISA, and NIST standards and practices. Individual measuring components of these facilities are certified traceable to NIST, and tandem meter arrangements are employed to continually verify flow data. Flow Line Options calibrations meet both static and dynamic traceability criteria. For an additional charge, calibrations for ±2% full scale accuracy can be certified per MIL-STD-45662.

FLOW RATE SELECTION

It is common practice to select a flowmeter placing normal flow at about 75% of full scale. However, the unique “over-read” feature of MEMFlo Flowmeters allows sizing meters to normal flows in the 85% – 100% range. This provides more precise flow measurement, as meter accuracy is generally a percentage of the 100% scale rating.

INTERCHANGEABILITY

A wide variety of capacities and different fluids can be accommodated in one meter body by insertion of different metering core tube and float combinations. Disassembly is quickly and easily accomplished while leaving the meter body in the pipeline (this facilitates cleaning). Scales must also be changed.

GPM @ 100%, SIZE 6	GPM @ 100%, SIZE 12
0.54 – 1.64	11.0 – 15.0
2.60 – 3.80	21.0 – 120.
5.40 – 23.0	

Table 1: 100% liquid flow capacities that are interchangeable within the same flowmeter body without removing the outlet restriction

In gas flowmeters, any capacity range offered in a given body size can be interchanged in this fashion. However, some low flow capacity liquid flowmeters incorporate a restriction in the outlet of the meter to facilitate filling of the sight tube. This restriction creates significant pressure drop if higher flows are used, and must be removed for higher flows. Table 1 shows the liquid flow capacity ranges which can be interchanged without removing the restriction.

Liquid Service

DEFINITION

GPM means Gallons per Minute. MEMFlo considers the practical rating parameter for water to be 70°F. in atmosphere as opposed to 4°C. in vacuum (a common basis for some flowmeters), which is seldom used in industrial applications. Thus, the standard MEMFlo gallon has a density of 62.236 lb/ft³, and weighs 8.3197 lbs. If the specific gravity of the liquid to be metered is referenced to water at 4°C. in vacuum, multiply that value by 1.0031 to correct to the MEMFlo base. Correction data is supplied with each MEMFlo Flowmeter to allow for other fluid conditions in the field. MEMFlo also offers special scaling for other densities or flow units.

SPECIFIC GRAVITY OR DENSITY

Density, viscosity, and temperature (which affects both density and viscosity) are the key variables affecting accuracy. Pressure effects are negligible, except for safety considerations, since in MEMFlo meter ranges, liquids are generally incompressible. The specific gravity or density of the metered liquid must be known to correctly size the flowmeter. This is necessary since flow indication is proportional to the square root of liquid density. Conversion formulae are provided in this specification.

VISCOSITY CONSIDERATIONS

Each MEMFlo Flowmeter for liquid service has a so-called “Viscosity Immunity Ceiling” (V.I.C.). In most cases, as long as the viscosity of the metered liquid is less than the V.I.C. of the particular flowmeter, accuracy will not be influenced by changes in viscosity. When the viscosity is greater the V.I.C., accuracy is influenced significantly, and the flowmeter must be calibrated for the particular fluid. In general, the higher the capacity of the flowmeter, the greater (higher V.I.C.) the range of immunity to viscosity variations.

However, the effects of viscosity on a given flowmeter are not always predictable. Two apparently similar liquids with comparable densities and viscosities may affect meter calibrations quite differently.

Table 2 below provides general guidelines for the typical maximum viscosity for meter models without affecting accuracy. If your viscosity exceeds the levels indicated, please consult Flow Line Options to determine if special modifications or calibrations are required. (NOTE: V.I.C.’s are applicable to liquid flows only.)

100% GPM, SIZE 6	CTS	100% GPM, SIZE 12	CTS
0.54 – 0.80	3	11.0 – 15.0	50
1.20 – 2.60	7	21.0 – 35.0	100
3.80 – 7.00	15	50.0 – 70.0	250
10.0 – 23.0	25	90.0 – 120.	500

Table 2: Average V.I.C., Centistokes, for standard “PVC & CPVC” flowmeters

DIRTY FLUIDS

Unlike tapered tube rotameters, PVC & CPVC Flowmeters have a sharp-edged float indicator disk that is always within a few thousandths of an inch of the cylindrical sight tube wall. Because of this near proximity, the edge of the disk remains visible regardless of flow rate even in many dirty fluids.

As a rule, the indicator disk is visible in most thinner oils and light colored liquids. Visibility in black, viscous liquids is unlikely, and the magnetic indication option should be ordered for these cases.



TEMPERATURE CONSIDERATIONS

A flowmeter should be selected for a specific operating temperature with the understanding that significant temperature changes will alter fluid density and meter accuracy in a manner that is not always predictable. Density changes with temperature in some liquids may not affect accuracy significantly because of partial or complete compensation by coincident viscosity changes. Consult Flo-Corp for specific recommendations if temperature extremes are anticipated.

SPECIAL & UNUSUAL CONSIDERATIONS — METERING EMULSIONS, SLURRIES, ETC.

The slotted cylinder design of MEMFlo Flowmeters allows them to accommodate fairly heavy emulsions, suspensions, and other mild slurries. Large particles classified as “sharp” or “abrasive” may cause periodic jamming of the float and require frequent flushing or cleaning (MEMFlo’s quick and easy disassembly facilitates this procedure if required). As with viscous fluids, larger capacity flowmeters are generally better able to handle slurry-like liquids. If the liquid to be metered is very viscous or contains significant levels of suspended particles, it may be desirable to forward a sample to Flow Line Options for analysis and specific recommendations.

False meter readings may result from dissolved or suspended gas bubbles that alter the effective liquid density, or with liquids being metered near the flash point. In the latter case, partial flashing to gas may occur in areas of even small pressure drop. Metering at or very near the flash point is potentially dangerous, and MEMFlo recommends against this practice.

Gas Service

DEFINITION

SCFM means Standard Cubic Feet per Minute. For MEMFlo standards, it is the weight of one cubic foot of the gas existing at 14.697 psia, 70°F. Thus, a Standard Cubic Foot actually defines the weight of the gas at any pressure-temperature (0.07492lbs for dry air), but defines a volume only at specified conditions. Thus, a flow of 1 SCFM is 0.075lbs. per minute at any pressure or temperature, but is 1 actual cubic foot per minute only at 14.697 psia, 70°F., and only 0.128 actual cubic feet per minute at 100 psig, etc.

Standard MEMFlo Flowmeters for gas service are rated for only one pressure-temperature condition — Dry Air @ 100 psig, 70°F. (Specific Gravity = 1.00 at 14.697 psia, 70°F.). Compensation for other pressures, temperatures, and specific gravities can be made using the sizing formula in this specification. Flow correction data is supplied with each MEMFlo Flowmeter to allow for changing service conditions in the field. MEMFlo also offers special scaling for other conditions.

SPECIAL & UNUSUAL CONSIDERATIONS

Generally, proper MEMFlo Flowmeter selection only requires compensation for different pressures, temperatures, and densities. Occasionally, other factors such as significant vapor content in the metered gas, gases near their flash point, low density gases metered at low pressures, vacuum applications, etc., require special compensations. Please consult Flow Line Options for specific recommendations if these or other special circumstances are anticipated.

Engineering Specification

Flowmeters shall be Flow Line Options “PVC” or “CPVC” Series or approved equal. Flowmeters shall have:

T-shaped body with vertical inlet and horizontal outlet. Bodies shall contain a slotted cylindrical metering tube.

Meter float with sharp-edged indicator disk moving in close proximity to sight tube wall, facilitating readout in dirty fluids at all flow levels. There shall be no springs or mechanical devices relating to flow indication.

Cylindrical flowmeter sight tube with static “O” ring oriented to allow pressure or vacuum operation. Sight tube is to be easily removable for cleaning or changing flow range without removing meter from the line.

Flowmeters shall have photo-etched scales in direct reading units or percent of flow, and shall be field-replaceable without recalibration.

Liquid Sizing Equations

Either
$$Q_m = Q_c \times \sqrt{\frac{\rho_c (\rho_f - \rho_m)}{\rho_m (\rho_f - \rho_c)}}$$

or

$$Q_m = Q_c \times \sqrt{\frac{d_c (d_f - d_m)}{d_m (d_f - d_c)}}$$

Where:

Q_m = GPM Liquid, Sp. Gr. = 1.00 (MEMFlo Base)
 Q_c = GPM of liquid to be metered
 ρ_m = Specific gravity per MEMFlo Std. (Related to water in atmosphere at 70°F. having Sp. Gr. = 1.00)
 ρ_c = Specific gravity of liquid being metered, same base as ρ_m
 d_m = Density of liquid, MEMFlo Base, #/ft³
 d_c = Density of liquid being metered, #/ft³
 ρ_f = Specific gravity of flowmeter float
 d_f = Density of flowmeter float per table below.

EXAMPLE: What is the equivalent flow to GPM Liquid, Specific Gravity = 1.00 (MEMFlo Base) of 35 GPM of an acid requiring a stainless meter, Specific Gravity = 1.50?

ANSWER:

$$Q_m = 35 \times \sqrt{\frac{1.50 (3.50 - 1.00)}{1.00 (3.50 - 1.50)}}$$

= 47.93 GPM

(A Size 12, 50 GPM model would be selected)

MEMFlo FLOAT SPECIFIC GRAVITIES & DENSITIES

MATERIAL	ρ_f	d_f
PVC & CPVC (avg)	3.50	217.8

FLOW EQUIVALENTS

One Gallon per Minute equals:	
231 Cu. Inches/Min.	3785 Cu. Centimeters/Min.
0.1337 Cu. Ft./Min.	3.785 Liters/Min.
0.02381 Barrels/Min. (oil)	0.0037854 Cu. Meters/Min.
128 Oz./Min.	8.32 lbs./Min. (Water)

Selecting "PVC & CPVC" Flowmeters

To choose a MEMFlo PVC or CPVC Flowmeter, please use the Sizing Equations to obtain the correct equivalent flow. Find either the closest or next larger flow (whichever you prefer) in the "Designator & 100% Flow Column" of the Capacity Tables.

Please review the Operating Limits in Table 5 to choose a model style rated for your service conditions. To build the proper model number, please see Page 7. When ordering or requesting a quotation, please specify:

Gas Sizing Equations

$$Q_m = Q_g \times 0.465 \times \sqrt{\frac{\rho_g \times T_g}{P_g}}$$

Where:

Q_m = SCFM DRY AIR @ 100 psig, 70°F. (MEMFlo Base)
 Q_g = SCFM of gas to be metered at operating conditions
 ρ_g = Specific gravity of gas to be metered at standard conditions (14.697 psia, 70°F.)
 T_g = Metering temperature, absolute, °R (460 + °F.)
 P_g = Metering pressure, absolute (14.697 + psig)

EXAMPLE: What is the equivalent flow to SCFM Dry Air @ 100 psig, 70°F. of 200 SCFM of nitrous oxide at 15 psig, 50°F. (Sp. Gr. = 1.53)?

ANSWER:

$$Q_m = 200 \times 0.465 \times \sqrt{\frac{1.53 \times 510}{29.697}}$$

= 476.7 SCFM

(A Size 12 or 16, 515 SCFM model would be selected)

FLOW & PRESSURE EQUIVALENTS:

1 SCFM equals	1 psig equals
0.02832 Cu. Meters/Min.	0.07031 Kg/Sq cm
1.6992 Cu. Meters/Hr.	27.70 In. Water Column
28.32 Liters/Min.	2.036 In. Hg
28,320 CC/Min.	51.714 mm Hg
60 Std. Cubic Feet/Hr.	6.895 Kpa
1728 Cu. Inches/Min.	0.06895 Bar
7.481 Gallons, U.S.	16.0 Oz./Sq. In.
6.229 Gallons, Imperial	0.06804 Atmospheres

NOTE: MEMFlo meters can also be used with vapors and other "non-perfect" gases. Contact Flow Line Options for assistance for these applications.

- The Fluid Name
- Density Or Specific Gravity
- Operating & Maximum Pressures & Temperatures
- Flow Rate (Normal, Minimum & Maximum)
- Desired Accessories Or Options (Alarms, Panel Mounts, Pressure Gages, Etc.)
- Special Or Unusual Considerations (Viscosity, Environmental Factors, Etc.)

Table 3: "PVC & CPVC" Flowmeter Capacities, Gpm Liquid, Sp. Gr. = 1.00

BODY SIZE	DESIGNATOR & 100% FLOW	OVER-READ FLOW	MIN. FLOW	SCALE INCREMENTS	ΔP, INCHES H ₂ O
6 (3/4")	0.54	0.58	0.025	0.005	5.5
	0.80	0.87	0.04	0.01	6.5
	1.20	1.25	0.06	0.01	7.5
	1.64	1.78	0.08	0.02	7.5
	2.60	2.82	0.10	0.02	14.2
	3.80	4.40	0.15	0.05	17.2
	5.40	6.10	0.20	0.05	17.2
	7.00	7.90	0.20	0.10	22.0
	10.0	12.0	0.20	0.10	22.0
	15.0	16.0	0.60	0.20	40.0
20.0	30.0	0.50	0.50	75.0	
12 (1 1/2")	11.0	13.0	0.50	0.10	13.8
	15.0	16.4	0.70	0.10	14.8
	25.0	28.0	1.00	0.20	17.5
	35.0	40.0	0.50	0.25	18.5
	50.0	60.0	1.00	0.50	26.0
16 (2")	70.0	75.0	2.00	0.50	80.0
	120.	130.	4.00	1.00	130.
24 (3")	50.0	60.0	2.00	0.50	15.0
	100.	120.	4.00	1.00	30.0
	150.	175.	7.00	1.00	40.0
	200.	240.	10.0	2.00	54.0
	300.	330.	15.0	2.50	150.
32 (4")	100.	120.	4.00	1.00	27.0
	150.	175.	7.00	1.00	36.0
	200.	240.	10.0	2.00	49.0
	300.	330.	15.0	2.50	53.0
	400.	450.	15.0	5.00	78.0
	500.	600.	20.0	5.00	145.

Table 4: "PVC & CPVC" Flowmeter Capacities, SCFM Dry Air, @ 100 PSIG, 70°F.

BODY SIZE	DESIGNATOR & 100% FLOW	OVER-READ FLOW	MIN. FLOW	SCALE INCREMENTS	ΔP, INCHES H ₂ O
6 (3/4")	7.40	8.90	0.30	0.10	1.5
	10.2	10.9	0.50	0.10	2.5
	14.0	15.2	0.70	0.20	3.1
	20.0	23.0	1.00	0.25	3.3
	26.0	28.0	1.00	0.50	3.4
	35.0	39.0	1.00	0.50	4.0
	50.0	55.0	2.00	0.50	4.5
	70.0	75.0	3.00	1.00	11.8
	85.0	100.	4.00	1.00	18.0
	125.	140.	6.00	1.00	22.0
160.	180.	6.00	2.00	45.0	
260.	290.	4.00	2.00	93.0	
12 (1 1/2")	40.0	43.0	2.00	0.50	1.4
	70.0	75.0	3.00	0.50	4.2
	100.	110.	4.00	1.00	7.6
	140.	168.	5.00	1.00	7.8
	175.	210.	5.00	1.00	7.6
	250.	320.	6.00	2.00	7.5
	310.	350.	2.00	2.00	12.0
	390.	470.	7.50	2.50	22.0
16 (2")	510.	610.	10.0	5.00	40.0
	750.	900.	35.0	5.00	70.0
	1000.	1200.	20.0	5.00	90.0
	600.	630.	30.0	5.00	15.0
	1000.	1200.	40.0	10.0	30.0
24 (3")	1750.	2000.	70.0	10.0	40.0
	2300.	2500.	100.0	20.0	54.0
	3500.	3700.	150.0	25.0	150.
	3000.	3500.	150.0	25.0	150.
32 (4")	1000.	1200.	40.0	10.0	27.0
	1750.	2000.	70.0	10.0	36.0
	2300.	2500.	100.0	20.0	49.0
	3500.	3700.	150.0	25.0	53.0
	4000.	4500.	150.0	50.0	78.0
	5000.	6000.	200.0	50.0	145.

Table 5: Operating Limits, “PVC & CPVC” Flowmeters*

BODY SIZE & DESCRIPTION	MAXIMUM NON-SHOCK WORKING PRESSURE, PSIG @ ° F.								
	70°	80°	100°	120°	140°	160°	180°	210°	
6 – All PVC, Threaded & Socket Connections	250	225	150	90	50	N.R.	N.R.	N.R.	
6 – All PVC, Flanged Connections	150	150	150	90	50	N.R.	N.R.	N.R.	
6 – PVC & Polysulfone, Threaded & Socket	300	295	205	130	70	N.R.	N.R.	N.R.	
6 – PVC & Polysulfone, Flanged	150	150	150	110	50	N.R.	N.R.	N.R.	
6 – PVC & Glass, Threaded & Socket	240	230	200	125	60	N.R.	N.R.	N.R.	
6 – PVC & Glass, Flanged	150	150	150	110	50	N.R.	N.R.	N.R.	
12/16 – All PVC, Threaded & Socket	170	150	105	65	40	N.R.	N.R.	N.R.	
12/16 – All PVC, Flanged Connections	150	150	105	65	40	N.R.	N.R.	N.R.	
12/16 – PVC & Polysulfone, Threaded Only	210	190	130	85	40	N.R.	N.R.	N.R.	
12/16 – PVC & Polysulfone, Socket Only	265	255	185	120	40	N.R.	N.R.	N.R.	
12/16 – PVC & Polysulfone, Flanged	150	150	150	110	40	N.R.	N.R.	N.R.	
12/16 – PVC & Glass, Threaded & Socket	180	180	130	85	40	N.R.	N.R.	N.R.	
12/16 – PVC & Glass, Flanged	150	150	150	110	40	N.R.	N.R.	N.R.	
24/32 – All PVC, Threaded & Socket	160	150	105	65	40	N.R.	N.R.	N.R.	
24/32 – All PVC, Flanged Connections	150	150	105	65	40	N.R.	N.R.	N.R.	
24 – PVC & Polysulfone, Threaded Only	190	170	120	75	40	N.R.	N.R.	N.R.	
32 – PVC & Polysulfone, Threaded Only	160	145	100	65	40	N.R.	N.R.	N.R.	
24/32 – PVC & Polysulfone, Socket Only	265	255	185	120	40	N.R.	N.R.	N.R.	
24/32 – PVC & Polysulfone, Flanged	150	150	150	110	40	N.R.	N.R.	N.R.	
24 – PVC & Glass, Threaded & Socket	180	170	120	75	40	N.R.	N.R.	N.R.	
32 – PVC & Glass, Threaded & Socket	160	145	100	65	40	N.R.	N.R.	N.R.	
24/32 – PVC & Glass, Flanged	150	150	150	110	40	N.R.	N.R.	N.R.	
6 – CPVC & Polysulfone, Threaded & Socket	300	300	280	230	180	130	80	50	
6 – CPVC & Polysulfone, Flanged	150	150	150	150	150	130	80	50	
6 – CPVC & Glass, Threaded & Socket	240	240	220	210	160	130	80	50	
6 – CPVC & Glass, Flanged	150	150	150	135	110	90	70	40	
6 – All CPVC, Threaded & Socket Connections	270	270	250	200	150	130	80	50	
6 – All CPVC, Flanged Connections	150	150	150	135	110	90	70	40	
12/16 – CPVC & Polysulfone, Threaded Only	210	200	180	145	115	85	50	30	
12/16 – CPVC & Polysulfone, Socket Only	265	255	250	200	160	120	75	45	
12/16 – CPVC & Polysulfone, Flanged	150	150	150	135	110	90	70	40	
12/16 – CPVC & Glass, Threaded Only	180	180	180	145	115	85	50	30	
12/16 – CPVC & Glass, Socket Only	180	180	180	180	160	120	75	45	
12/16 – CPVC & Glass, Flanged	150	150	150	135	110	90	70	40	
12/16 – All CPVC, Threaded Only	180	180	170	145	115	85	50	30	
12/16 – All CPVC, Socket Only	180	180	180	170	150	110	75	45	
12/16 – All CPVC, Flanged Connections	150	150	150	135	110	90	70	40	
24 – CPVC & Polysulfone, Threaded Only	180	180	160	135	105	75	50	30	
32 – CPVC & Polysulfone, Threaded Only	160	155	135	110	90	65	40	25	
24/32 – CPVC & Polysulfone, Socket Only	265	255	250	200	160	120	75	45	
24/32 – CPVC & Polysulfone, Flanged	150	150	150	135	110	90	70	40	
24 – CPVC & Glass, Threaded & Socket	180	180	160	135	105	75	50	30	
32 – CPVC & Glass, Threaded & Socket	160	155	135	110	90	65	40	25	
24/32 – CPVC & Glass, Flanged	150	150	150	135	110	90	70	40	
24 – All CPVC, Threaded Only	160	160	140	125	105	75	50	30	
32 – All CPVC, Socket Only	225	215	210	160	150	120	75	45	
24/32 – All CPVC, Flanged Connections	150	150	150	135	110	90	70	40	

N.R. = NOT RECOMMENDED

* Operating limits given are based on water or air. For more severe service, corrosives, and other media and/or environmental factors, an additional correction factor down-rating these limits may be required.

Limits are based on testing and practical experience. Possible extreme application conditions cannot be foreseen. Thus, data is offered only as a guide. It in no way constitutes a specific recommendation or warranty expressed or implied.

The operating limits should not be exceeded under any circumstances. If there is any doubt regarding the safe operating limit for a specific application, please consult Flow Line Options prior to installation and pressurization of the flow device..

The example shows how to order an all PVC flowmeter for 50 GPM with 2" flanged connections, EPR "O" ring, corrosion resistant mylar scale, and MEMFlo's Safety Guard. The model number is written as a 16APPFG50.0CLE.

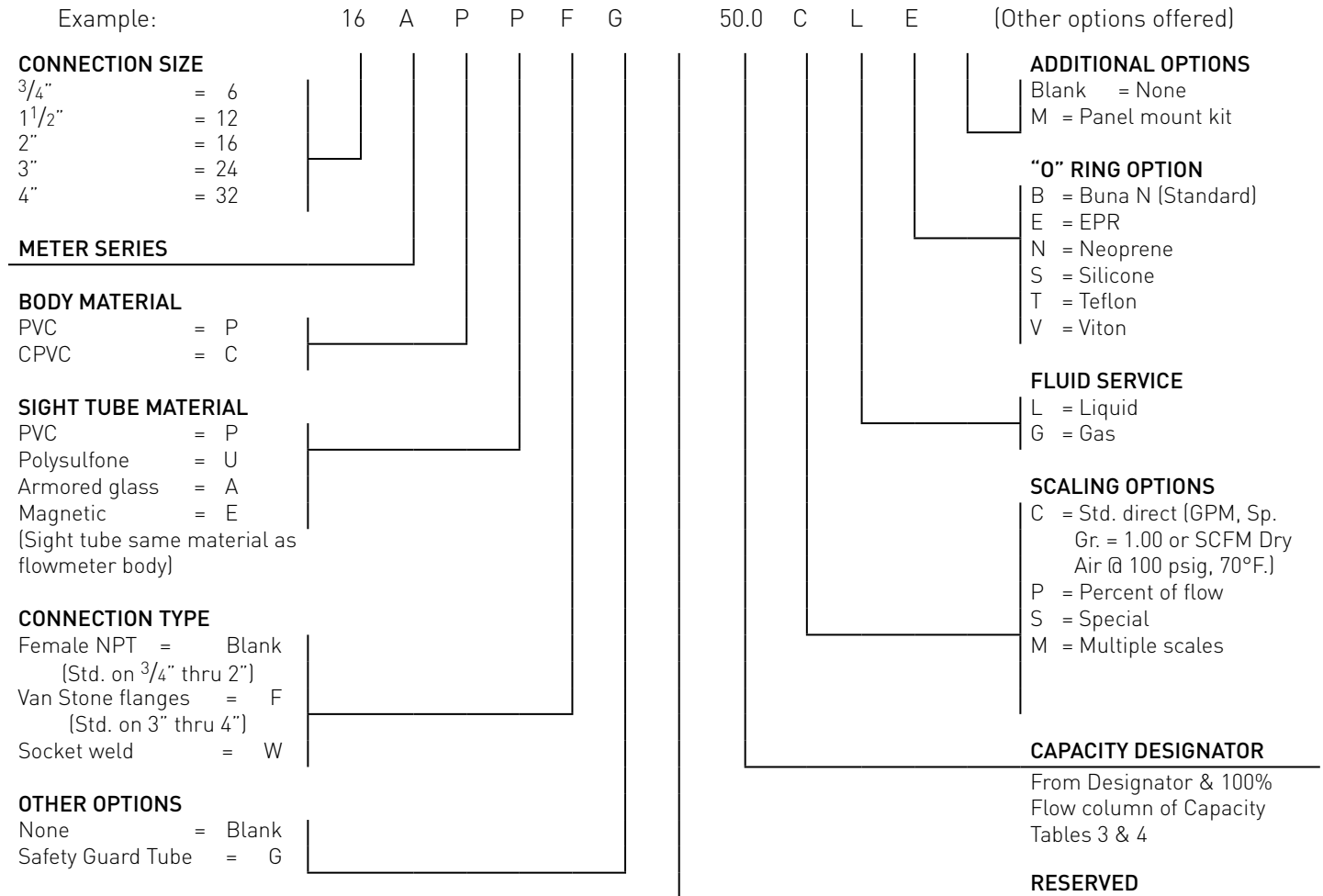

SPECIAL RECOMMENDATIONS FOR MEMFlo PVC & CPVC FLOWMETERS & PLASTIC PIPING SYSTEMS

- Do not install threaded metal pipe into plastic flowmeters, as it is likely to cause the body to leak or crack over time.
- If solvent cementing is being done in the vicinity of a MEMFlo flowmeter with a Polysulfone sight tube, the sight tube should be removed from the meter and stored away from the cement fumes.
- Plastic flowmeters should not be exposed to direct sunlight. Heat buildup can cause PVC units to weaken and even distort, and ultraviolet radiation may also have an adverse effect. Plastic meters installed outdoors should be shaded.
- PVC and CPVC are not recommended for compressed air lines or gas service at high pressures. If the pressure is 15 psig or less, either plastic is considered acceptable for air service.



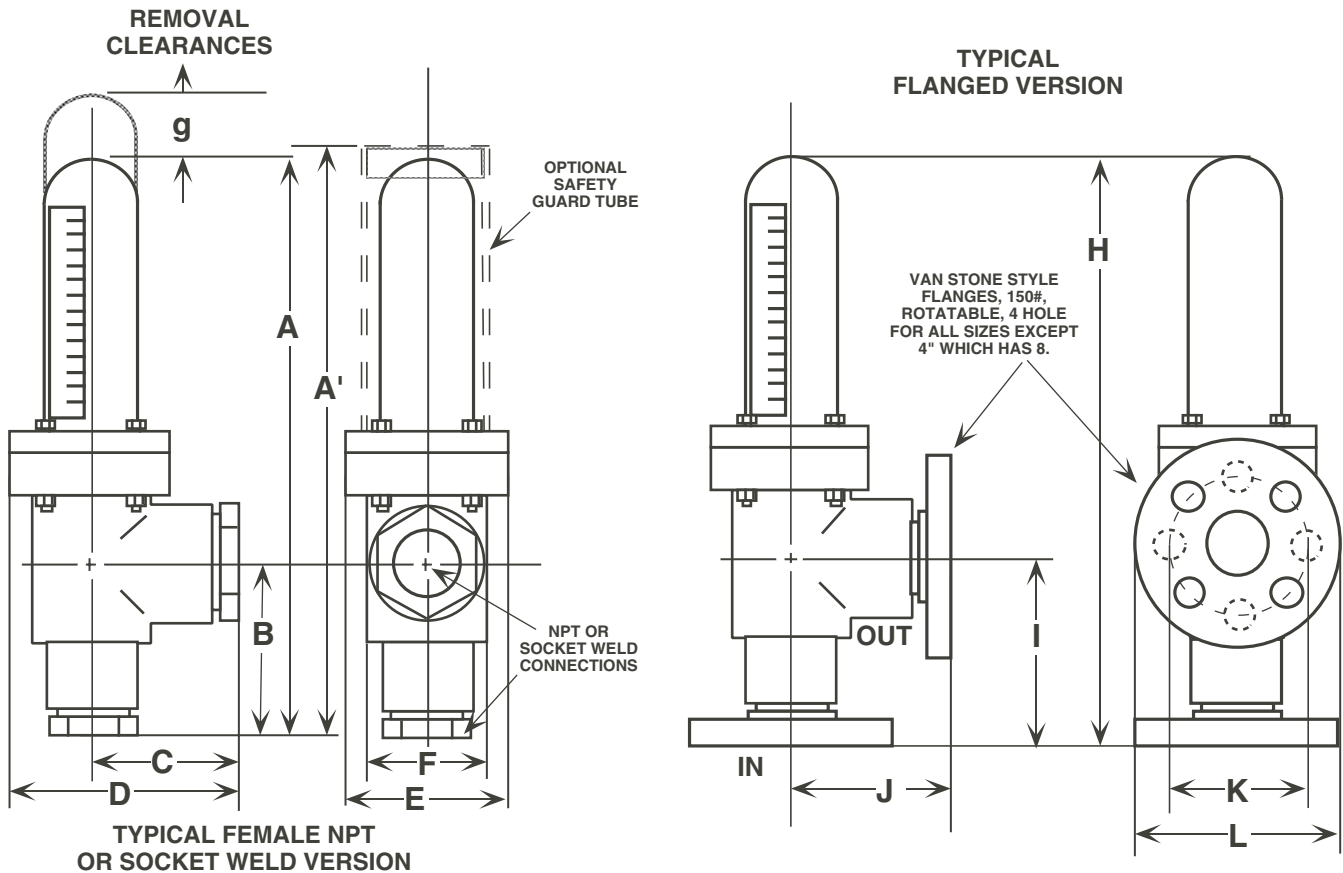

Dimensions: "PVC & CPVC" Flowmeters

Model TYPE	A	A'	B	C	D	E	F	g	Female PIPE	Model TYPE	H	I	J	K	L	150# Flange
6APP	11.02	11.52	3.38	2.82	4.66	3.60	2.54	3.00	3/4"	6APPF	12.27	4.63	4.07	2.75	3.88	3/4"
12APP	16.93	17.08	4.25	4.00	6.45	5.03	3.45	5.00	1 1/2"	12APPF	18.63	5.95	5.70	3.88	5.00	1 1/2"
16APP	16.93	17.08	4.25	4.00	6.45	5.03	3.45	5.00	2"	16APPF	18.75	6.07	5.82	4.75	6.00	2"
24APP	23.10	23.25	7.90	7.90	11.60	5.03	4.30	5.00	3"	24APPF	21.30	6.10	6.10	6.00	7.50	3"
32APP	27.42	27.57	9.79	9.79	14.29	5.44	5.44	5.00	4"	32APPF	25.13	7.50	7.50	7.50	9.00	4"
6APA	11.86	12.36	3.38	2.82	4.66	3.60	2.54	3.00	3/4"	6APAF	13.11	4.63	4.07	2.75	3.88	3/4"
12APA	18.17	18.32	4.25	4.00	6.45	5.03	3.45	5.00	1 1/2"	12APAF	19.87	5.95	5.70	3.88	5.00	1 1/2"
16APA	18.17	18.32	4.25	4.00	6.45	5.03	3.45	5.00	2"	16APAF	19.99	6.07	5.82	4.75	6.00	2"
24APA	24.34	24.49	7.90	7.90	11.60	5.03	4.30	5.00	3"	24APAF	22.54	6.10	6.10	6.00	7.50	3"
32APA	28.66	28.81	9.79	9.79	14.29	5.44	5.44	5.00	4"	32APAF	26.37	7.50	7.50	7.50	9.00	4"

Notes: All dimensions are in inches, with a tolerance of ± 0.10 " due to variance on purchased components. Flow Line Options can also supply meters with other size flanges, special inlet & outlet piping runs, adapters, etc. For pricing, please contact us.

Approximate Shipping Weights

6APP	3 pounds	12 or 16APP	9 pounds	6APPF	3 pounds	12 or 16APPF	9 pounds
24APP	14 pounds	32APP	18 pounds	24APPF	14 pounds	32APPF	18 pounds

